

# F.I.F.O Accumulator

## FEATURES

- Carousel Design
- Handles a full range of container and product sizes.
- Patented Rwave Transfer Technology facilitates gentle and precise product placement.
- Front or Side Loading Capabilities
- Optional Graphical User Interface with Reporting / Data Collection.
- Intuitive Operator Alarms and Displays for Operation and Maintenance.

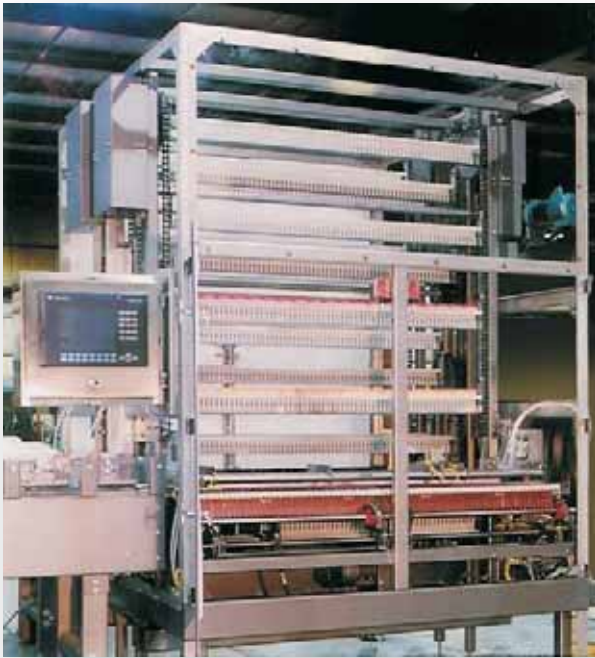
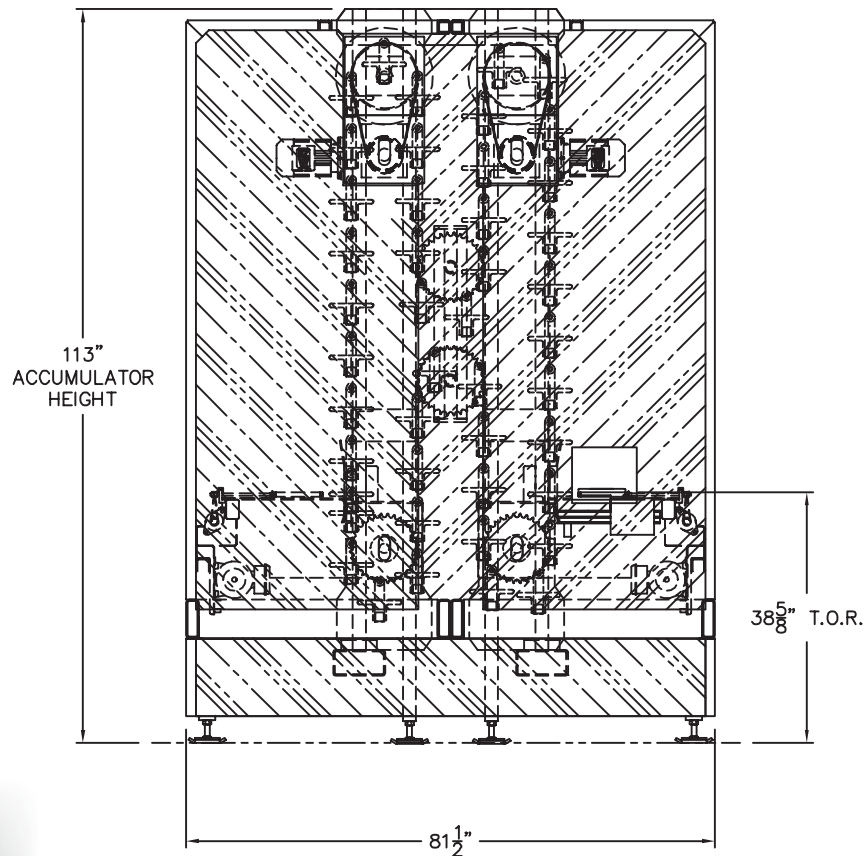

**Rwave® Transfer**

The F.I.F.O. First-In-First-Out Accumulator utilizes a carousel design and can handle a full range of container and product types and sizes. Fitted with our patented Rwave transfer system, it gently places products on lift rails, eliminating any pushing and allowing for two rows of product to be accumulated on every rail.

FIFO features a compact footprint while maintaining hundreds of feet of accumulation. It's open access and clear visibility raises operator safety and efficiency.

\* DIMENSIONS ARE IN INCHES AND ARE FOR REFERENCE ONLY.

